

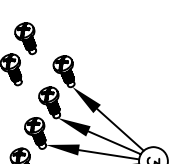

ITEM NO.	DESCRIPTION	QTY.
1	STAINLESS STEEL FACEPLATE	1
2	MODULAR PLASTIC BEZEL	1
3	#6-32 MOUNTING SCREW	6

CATALOG NUMBER	FINISH	DESCRIPTION
IMSS3	BRUSHED	STATION 3-GANG STAINLESS STEEL FACEPLATE

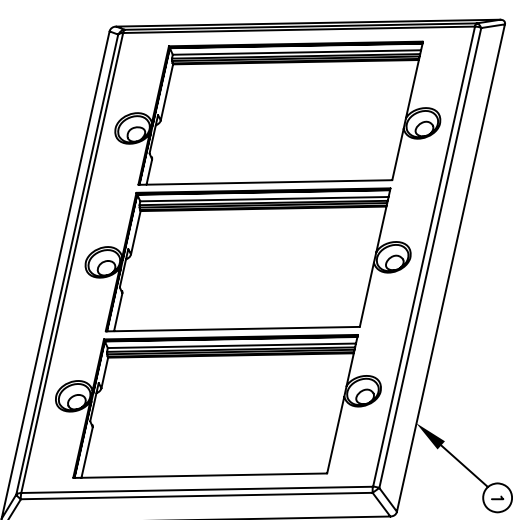
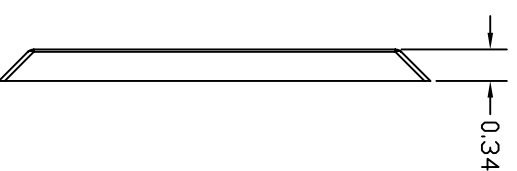
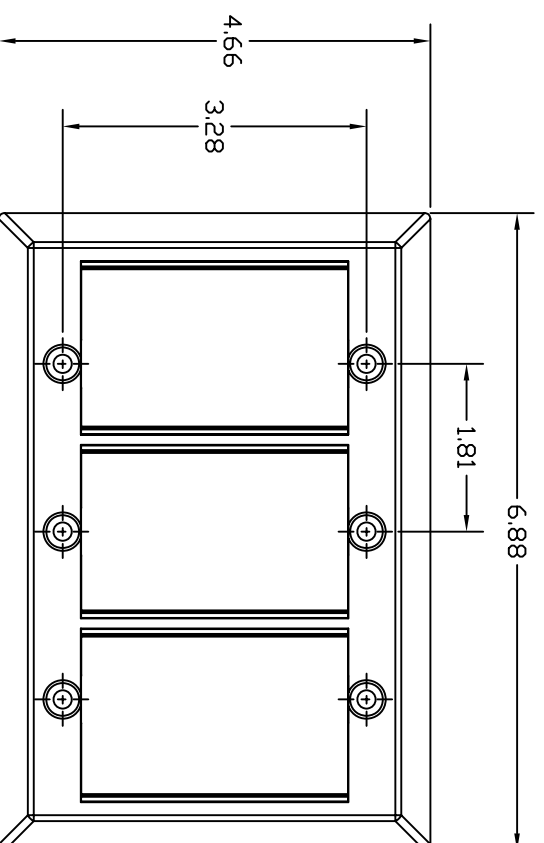

- NOTES:**
1. SPECIFICATIONS SUBJECT TO CHANGE WITHOUT NOTICE.
 2. COMPATIBLE WITH ALL I STATION MODULES.
 3. UL & cUL LISTED.

REV.	ECN	DATE	DESCRIPTION	CHG BY	APPD BY
B	6667	10/21/09	UPDATED DIMENSIONS	CG	

Created on AUTOCAD		DIMENSIONING AND TOLERANCE PER ANSI Y14.5M-1982 UNLESS OTHERWISE SPECIFIED, DIMENSIONS ARE IN INCHES (MM). TOLERANCES .XX = ±.01 (.25) .XXX = ±.005 (.127) .XXXX = ±.0025 (.0635) ANGLE TOL .±1°	
IN ACCEPTING OUR DRAWINGS, BLUEPRINTS, OR SUPPORTING DOCUMENTATION FOR QUOTATION OR OTHER PURPOSES, YOU AGREE NOT TO DISCLOSE TO OTHERS THE IDEAS, INFORMATION, OR DESIGNS SHOWN HEREIN, AND THAT YOU WILL MAKE NO USE OF SAME WITHOUT PERMISSION		PROJECT REFERENCE: 032-09 MATERIAL: 430 STAINLESS STEEL	
DRAWN BY: C. GRIBBLE 8/27/09		 Hubbell Premise Wiring HUBBELL INCORPORATED (Delaware) 14 Lord's Hill Road, Stonington, Connecticut 06378	
CHECKED BY:		TITLE: I STATION STAINLESS STEEL FACEPLATE 3-GANG	
APPROVED BY:		SIZE: B DRAWING NO. HWS12808C REV. B SCALE: 1/2 SHEET 1 OF 1	